

HIGHLEAD

GA2688-L

Long Arm Cylindrical Bed

Compound-Feed

Extral Heavy Duty

Instruction Manual
Parts Catalog

SHANGHAI HUIGONG NO.3 SEWING MACHINE FACTORY

From the library of: Superior Sewing Machine & Supply LLC

--- CONTENT ---

1、PRECAUTIONS BEFORE STARTING OPERATION	2
(1) Safety Precautions	2
(2) Precautions before Starting Operation	2
(3) Precautions for Operating Conditions	2
2、MAIN SPECIFICATION	2
3、PREPARATION FOR OPERATION	3
4、REPLACE NEEDLES	4
5、WINDING OF BOBBIN THREAD	4
6、ADJUSTMENT OF THE BOBBIN WINDER	4
(1) In case of uneven winding	4
(2) Winding amount of thread	4
(3) Winding strength	4
7、THREADING	4
8、REMOVING AND INSERTING THE BOBBIN	5
9、ADJUSTING THE THREAD TENSION	5
10、ADJUSTMENT OF PRESSER FOOT PRESSURE	5
11、ADJUSTMENT OF WALKING FOOT AND PRESSER FOOT	6
12、ADJUSTMENT OF STITCH LENGTH AND FORWARD/BACKWARD SEWING	6
13、FEED DOG HEIGHT	6
14、ADJUSTING THE HEIGHT OF THE NEEDLE BAR	6
15、USING OF THE HAND WHEEL	7

1. PRECAUTIONS BEFORE STARTING OPERATION

1) Safety Precautions:

- (1) When turning the power on, keep your hands and fingers away from the area around/under the needle and the area around the balance wheel.
- (2) Power must be turned off when the machine is not in use, or when the operator leaves the seat.
- (3) Power must be turned off when tilting the machine head, installing or removing the “V” belt, adjusting the machine, or when replacing.
- (4) Avoid placing fingers, hairs, bars etc., near the balance wheel, “V” belt, bobbin winder balance wheel, or motor when the machine is in operation.
- (5) Do not insert fingers into the thread take-up cover, under/around the needle, or balance wheel when the machine is in operation.
- (6) If a belt cover, finger guard, eye guard are installed, do not operate the machine without these safety devices.

2) Precautions before Starting Operation:

- (1) If the machine’s oil pan has an oil sump, never operate the machine before filling it.
- (2) If the machine is lubricated by a drop oiler, never operate the machine before lubricating.
- (3) When a new sewing machine is first turned on, verify the rotational direction of the balance wheel with the power on. (The balance wheel should rotate counter-clockwise when viewed from the balance wheel)
- (4) Verify the voltage and (single or three) phase with those given on the machine nameplate.

3) Precautions for Operating Conditions:

- (1) Avoid using the machine at abnormally high temperature (35°C or higher) or low temperature (5°C or lower) .
- (2) Avoid using the machine in dusty conditions.

2. MAIN SPECIFICATIONS

Max. Speed		800 rpm
Needle		DY×3 26#
Needle Bar Stroke		56 mm
Thread Take-up Lever Stroke		96 mm
Stitch Length		11 mm
Presser-Foot Stroke	By Hand	13 mm
	By Knee	20 mm

3、 PREPARATION FOR OPERATION

1) Cleaning the machine

Before leaving the factory, the machine parts are coated with rust-preventive grease, which may be hardened and contaminated by dust during storage and shipment. This grease must be removed with gasoline.

2) Examination

Though every machine is confirmed by strict inspection and test before leaving the factory, the machine parts may be loose or deformed after long distance transportation with jolt. A thorough examination must be performed after cleaning the machine. Turn the balance wheel to see if there is running obstruction, parts collision, uneven resistance or abnormal noise. If these exist, adjustment must be made accordingly before run-in operation.

3) Lubrication (Fig.1.1、 Fig.1.2、 Fig.1.3)

When a new sewing machine is used for the first time, or sewing machine left out of use for considerably long time is used again, replenish a suitable amount of oil to the portions indicated by arrow in below figure.

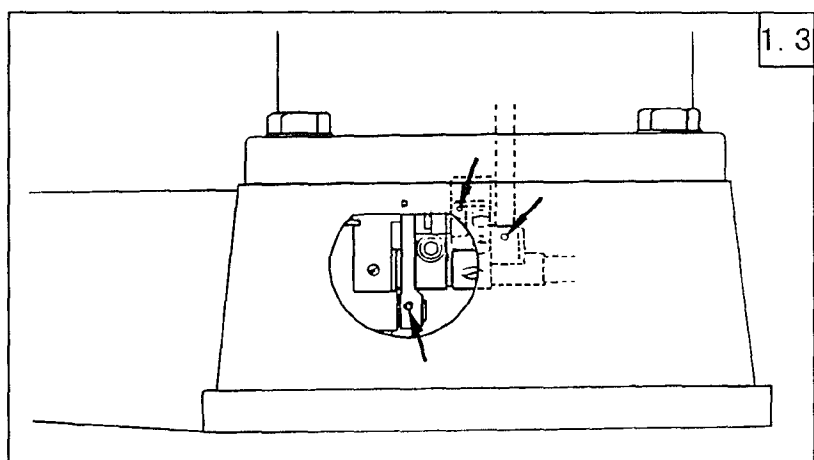
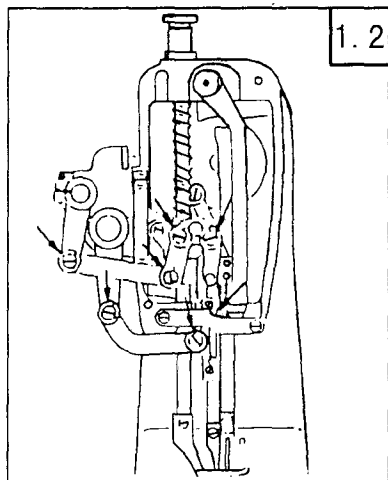
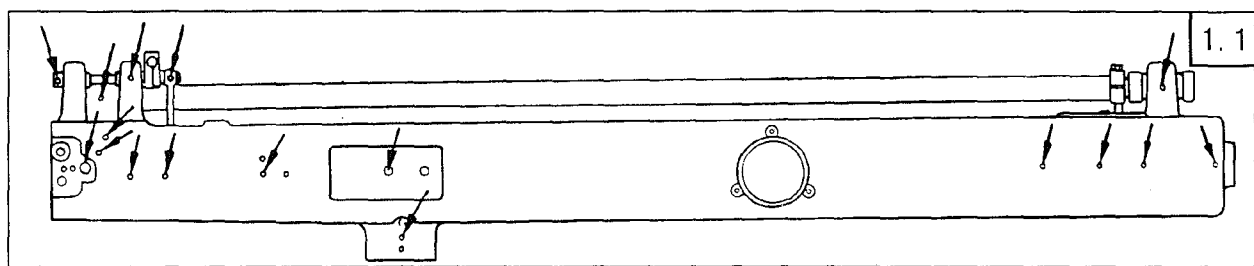

CAUTION: Please use white spindle oil.

Always keep the presser foot lifted before attempting a dry run.

4) Testing

In order to get the best working situation, run the sewing machine in a low speed for about 1 month after lubricated fully. Then increase the speed to the need one.

CAUTION: Before using the following procedures, be sure to turn the power switch off.

The needle used by this sewing machine is DY×3 26#. During operation, proper needle can be chosen according to the sewing thread. (the sewing thread should be able to pass the pinhole.)

4. REPLACE NEEDLES (Fig.2)

CAUTION : Before using the following procedures, be sure to turn the power switch off.

The needle used by this sewing machine is DY×3 26#. Turn the balance wheel to lift needle bar to the upper end of its stroke. Loosen needle clamp screw (A). While keeping the long groove of the needle leftward fully insert the needle shank up to the bottom of the needle socket. Then tighten needle clamp screw (A).

Note: Fig. (b): insufficient insertion.

Fig. (c): wrong direction of long groove.

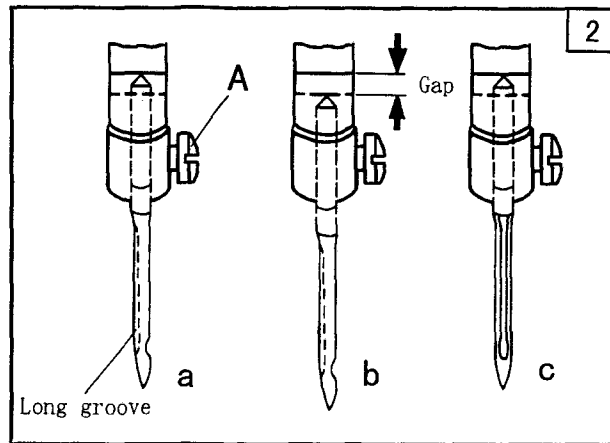

5. WINDING OF BOBBIN THREAD (Fig.3)

1) Push the bobbin 3 on the bobbin winder shaft as far as it will go.

2) Bring the thread forward toward the bobbin and wind from below in clockwise direction several times around the bobbin.

3) Push the lever 5 toward other side so that the driving wheel and driven wheel will engage and then start the machine.

4) The driven wheel will automatically be free from the driving wheel and stop after the bobbin is filled with thread.

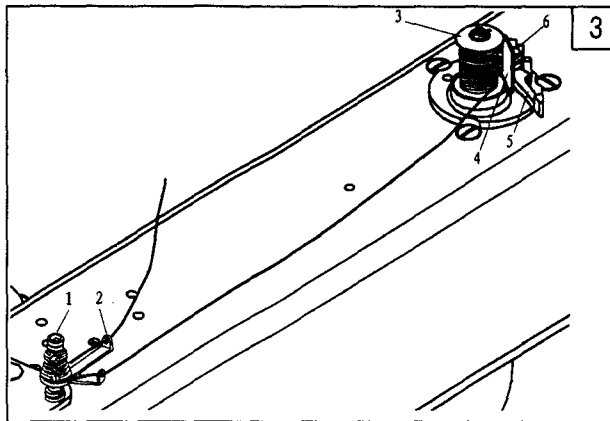

6. ADJUSTMENT OF THE BOBBIN WINDER (Fig.3)

WINDER (Fig.3)

1) In case of uneven winding

If the thread does not wind evenly on the bobbin, loosen the nut 1 and move the bracket 2 to the right or to the left as may be required, then tighten the nut.

2) Winding amount of thread

Adjusting 6 can increase or decrease the amount of thread wound on the bobbin.

3) Winding strength

Strength of the winding can be adjusted with the nut 1.

7. THREADING (Fig.4)

Raise the needle bar to its highest position and route the upper thread in the order illustrated below.

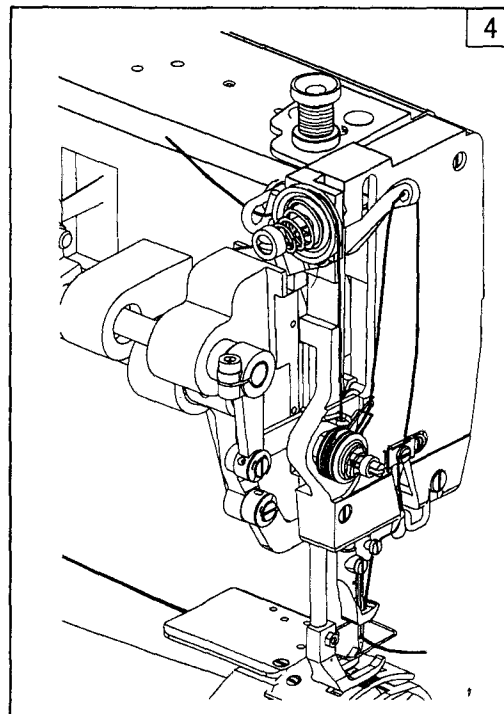

8. REMOVING AND INSERTING THE BOBBIN

(1) Removing: Open the shuttle race cap and the bobbin holder, then take out the bobbin.

(2) Installation: Put the bobbin in the rotary hook case, Permit about 5 cm of bobbin thread to hand down freely. Install the bobbin in the bobbin case so that the thread wound direction is clockwise. Then close the rotary hook and the shuttle race cap.

9. ADJUSTING THE THREAD TENSION (Fig.5)

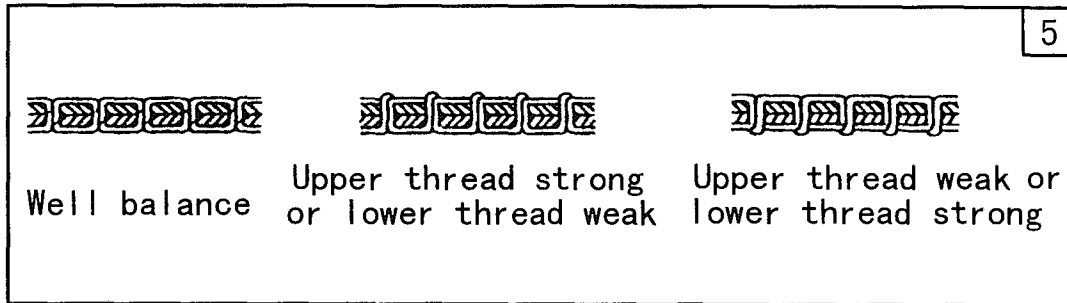

For ordinary stitching, the tension of the upper and the lower threads should be equal.

(1) Tension of the Upper thread

Before adjusting the tension of the upper thread, be sure that presser foot is let down. To adjust tension, turn serrated nut on tension device to the right (clockwise) to increase tension and to the left (counter-clockwise) if you desire to decrease the tension.

(2) Tension of the lower thread

The lower thread tension is controlled by the larger screw near the end of the spring at the outside of the bobbin case. Turning this screw to the right (clockwise) will increase the thread tension, while turning it to the left (counter-clockwise) will decrease the tension.

10. ADJUSTMENT OF PRESSER FOOT PRESSURE (Fig.6)

(1) Pressure should be adjusted according to the material to be sewn.

(2) Pressure on both the walking foot and the presser foot can be adjusted. (The adjusting screw has been set before shipment.)

(3) Sewing pressure should be adjusted to the minimum required strength.

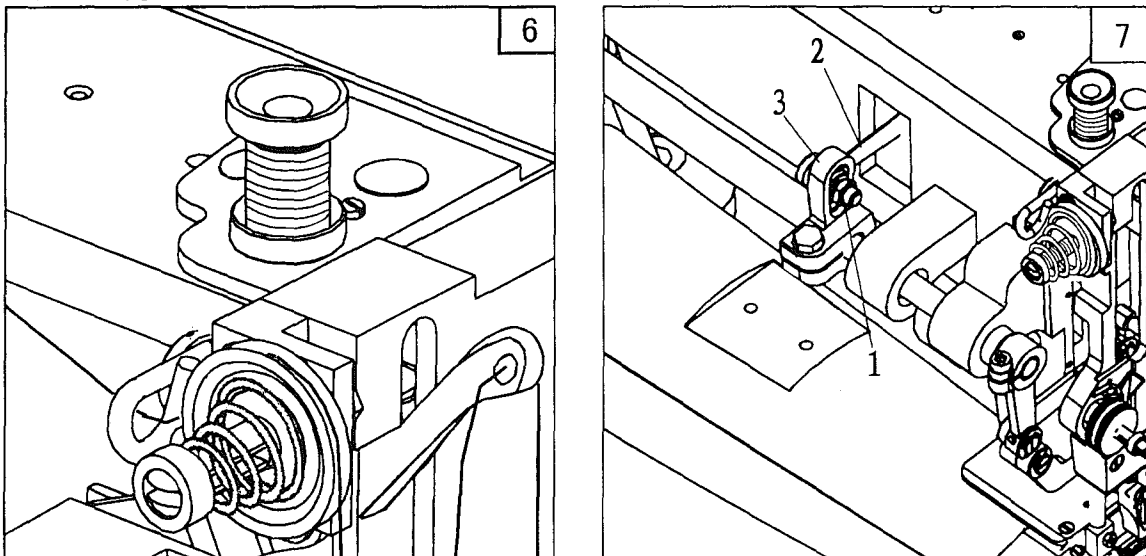

11、 ADJUSTMENT OF WALKING FOOT AND PRESSER FOOT (Fig.7)

(1) The alternating movement on the walking foot and presser foot can be adjusted by changing the position relations of the parts of the presser foot lifting mechanism.

(2) Changing the position relation of the connecting link 2 and the crank 3 can complete the adjustment.

(3) Adjustment should be changed according to the thickness of the material to be sewn.

12、 ADJUSTMENT OF STITCH LENGTH AND FORWARD/BACKWARD

SEWING (Fig.8)

(1) Adjusting the stitch length adjusting bolt can change the stitch length.

(2) Stitch length can be adjusted between 0-11mm.

(3) Setting the stitch length adjusting bolt above “0” can backstitch.

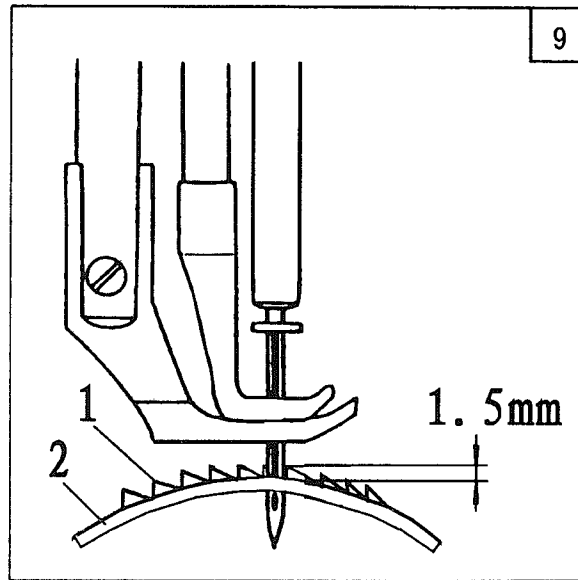
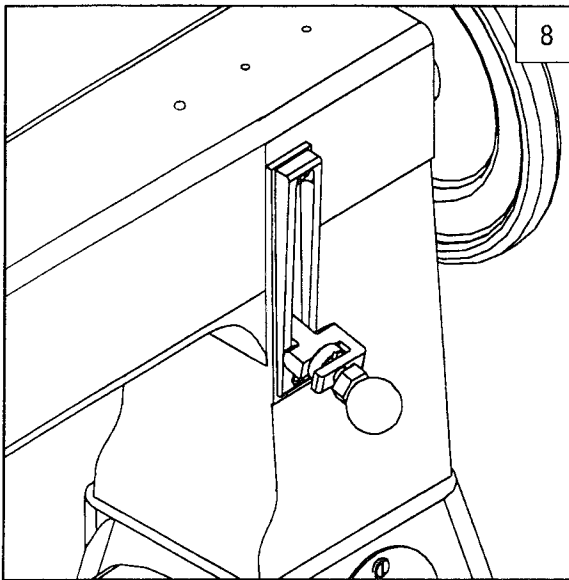

13、 FEED DOG HEIGHT (Fig.9)

The feed dog should be 1.5 mm higher than the vertex of the needle plate. Adjustment of the feed dog height can be done as follows:

(1) Turn the machine balance wheel so as to raise the feed dog to its highest point.

(2) Loosen the screw of the feed dog and adjust the height by raising or lowering it. Then tighten the screw.

14、 ADJUSTING THE HEIGHT OF THE NEEDLE BAR (Fig.10)

When the needle bar is at its highest point, normally the measurement between the highest point of the needle plate and the needlepoint is 28 mm. When this distance need to be adjusted, the steps is

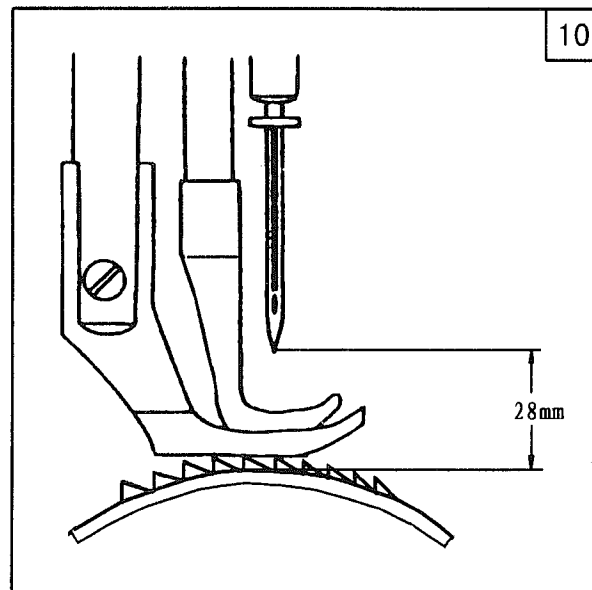

as follows:

- (1) Take down the face plate, adjust the needle bar to its highest position.
- (2) Loosen the screw of needle bar connecting stud screw.
- (3) Adjust the needle bar to the right position.
- (4) Tighten the screw.

15、 USING OF THE HAND WHEEL(Fig.11)

If you want to change the position of the needle when the machine is not running, you can use the hand wheel. Just push the hand wheel in and rotate it.

Caution: forbid to push the hand wheel when the machine is running.

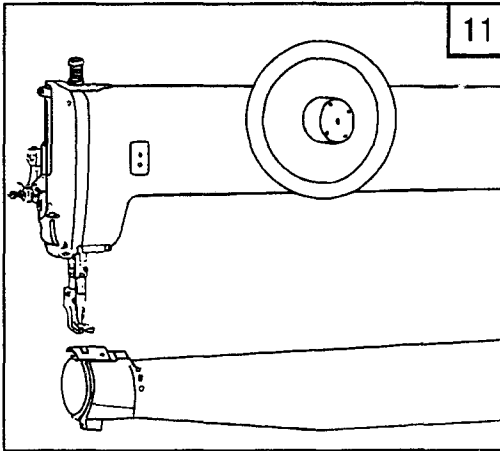

A.ARM BED AND ITS ACCESSORIES

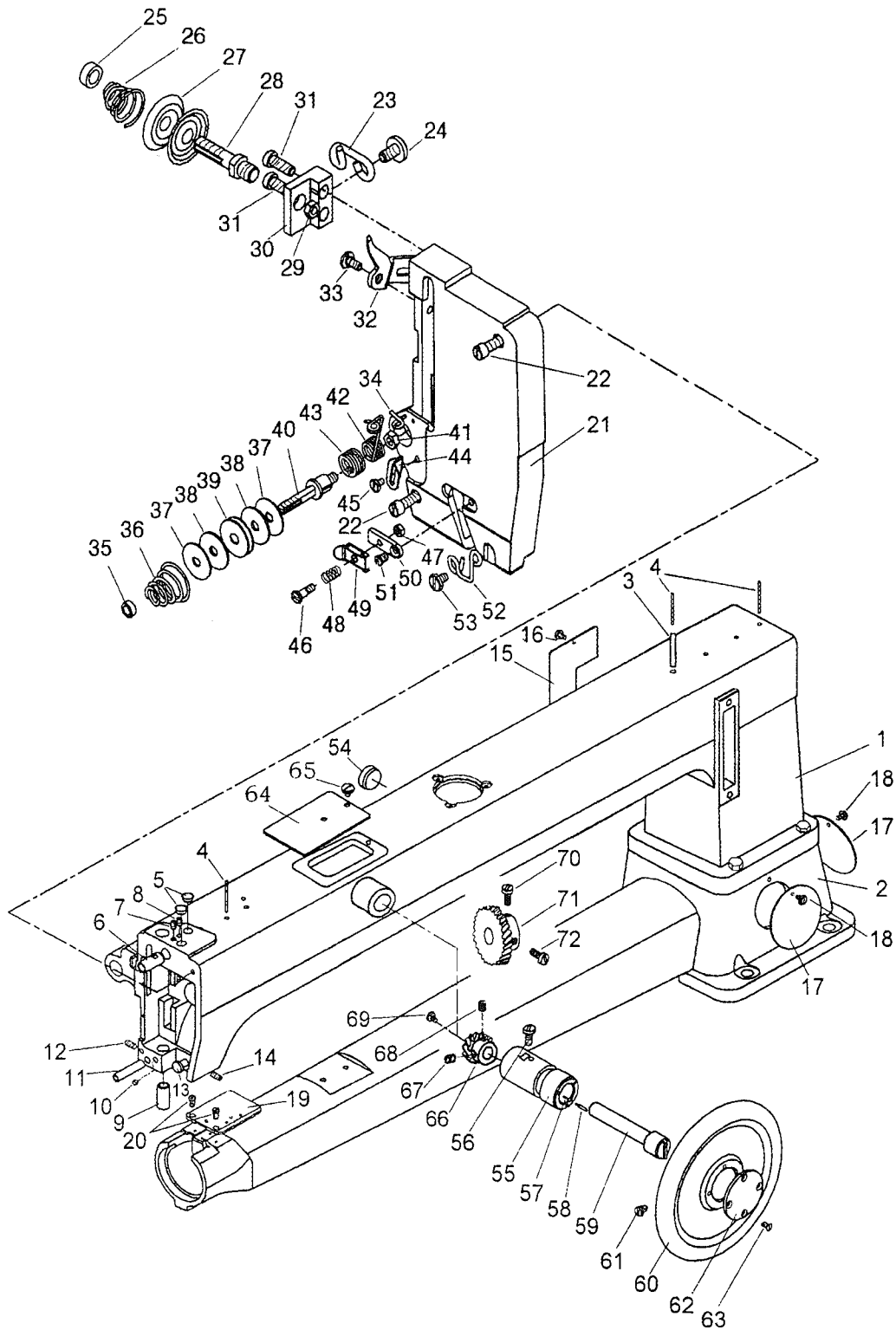

A.ARM BED AND ITS ACCESSORIES

Fig. No.	Part No.	Description	Pcs.	Remarks
A01	H8908B8001	Arm	1	
A02	H8910B8001	Bed	1	
A03	H7215B8001	Oil pipe	1	
A04	H7216B8001	Oil wick	3	
A05	HA307B0674	Rubber plug	2	
A06	H7217B8001	Needle bar guide bracket stud bushing	1	
A07	HA100C2020	Set Screw	1	SM15/64(28)×10
A08	HA100C2020	Set Screw	1	SM15/64(28)×10
A09	H7218B8001	Presser bar bushing	1	
A10	HA305E0662	Set Screw	1	SM15/64(28)×4.5
A11	H7219B8001	Pin	1	
A12	HA100C2020	Set Screw	1	SM15/64(28)×10
A13	H7220B8001	Mandril of needle bar guide bracket	1	
A14	H2405D0664	Set Screw	1	SM15/64(28)×14
A15	H7225B8001	Arm side cover	1	
A16	HA100B2060	Screw	1	SM11/64(40)×9
A17	H7228B8001	Round cover	2	
A18	HA100B2060	Screw	2	SM11/64(40)×9
A19	H7235B8001	Worktable for accessories	1	
A20	HA7311C806	Screw	2	SM11/64(40)×9
A21	H7236B8001	Face plate	1	
A22	H7238B8001	Screw	2	SM15/64(28)×22
A23	H7240B8001	Thread guide	1	
A24	H3410C301K	Screw	1	SM9/64(40)×6.5
A25	HA115B0702	Nut	1	
A26	H7241B8001	Tension spring	1	
A27	HA310B0705	Tension disc	2	
A28	H7242B8001	Tension screw stud	1	SM9/32(28)
A29	H2010J0066	Tension nut	1	SM9/32(28)
A30	H7243B8001	Thread tension regulator complete base	1	
A31	HA111G0683	Screw	2	SM11/64(40)×12
A32	H7244B8001	Tension releasing disc	1	
A33	H7245B8001	Screw	1	SM3/16(28)
A34	H7246B8001	Thread guide	1	
A35	HA115B0702	Tension nut	1	
A36	H7241B8001	Tension spring	1	
A37	H7248B8001	Washer	2	
A38	H7249B8001	Felt	2	
A39	H7250B8001	Damping plate	1	
A40	H7251B8001	Tension screw stud	1	SM15/64(28)
A41	HA710N0683	Nut	1	SM15/64(28)
A42	H7253B8001	Thread take-up spring	1	
A43	H7254B8001	Spring	1	

A.ARM BED AND ITS ACCESSORIES

Fig. No.	Part No.	Description	Pcs.	Remarks
A44	H7255B8001	Thread take-up spring guide plate	1	
A45	H3410C301K	Screw	1	SM9/64(40)×6.5
A46	H7257B8001	Screw	1	SM1/8(44)
A47	H7258B8001	Nut	1	SM1/8(44)
A48	H7259B8001	Tension spring	1	
A49	H7260B8001	Tension disc	1	
A50	H7261B8001	Thread tension regulator complete base	1	
A51	HA7311CC06	Screw	1	SM9/64(40)×6
A52	H7262B8001	Thread guide	1	
A53	H3410C301K	Screw	1	SM9/64(40)×6.5
A54	HA300B2100	Rubber plug	1	
A55	HE957B8001	Bushing	1	
A56	HE040D8001	Screw	1	SM17/64(24)×17.5
A57	HE962B8001	Spring	3	
A58	HE961B8001	Pin	3	
A59	HE965B8001	Hand whell shaft	1	
A60	HE963B8001	Hand wheel	1	
A61	HE966B8001	Screw	2	SM1/4(32)×6
A62	HE965B8001	Cover	1	
A63	HA700F2100	Screw	4	SM11/64(40)
A64	HE951B8001	Top cover	1	
A65	H2015I0065	Screw	1	SM3/16(28)
A66	HE958B8001	Gear	1	
A67	HE017G8001	Screw	1	SM1/4(32)×5.5
A68	HE023C8001	Screw	1	SM1/4(32)×5.5
A69	HE007C8001	Screw	1	SM17/64(24)×11
A70	HE960B8001	Screw	1	SM1/4(32)×11
A71	H8921B8001	Gear	1	
A72	HE022G8001	Screw	1	SM1/4(32)×10.5

B.NEEDLE BAR AND THREAD TAKE-UP MECHANISM

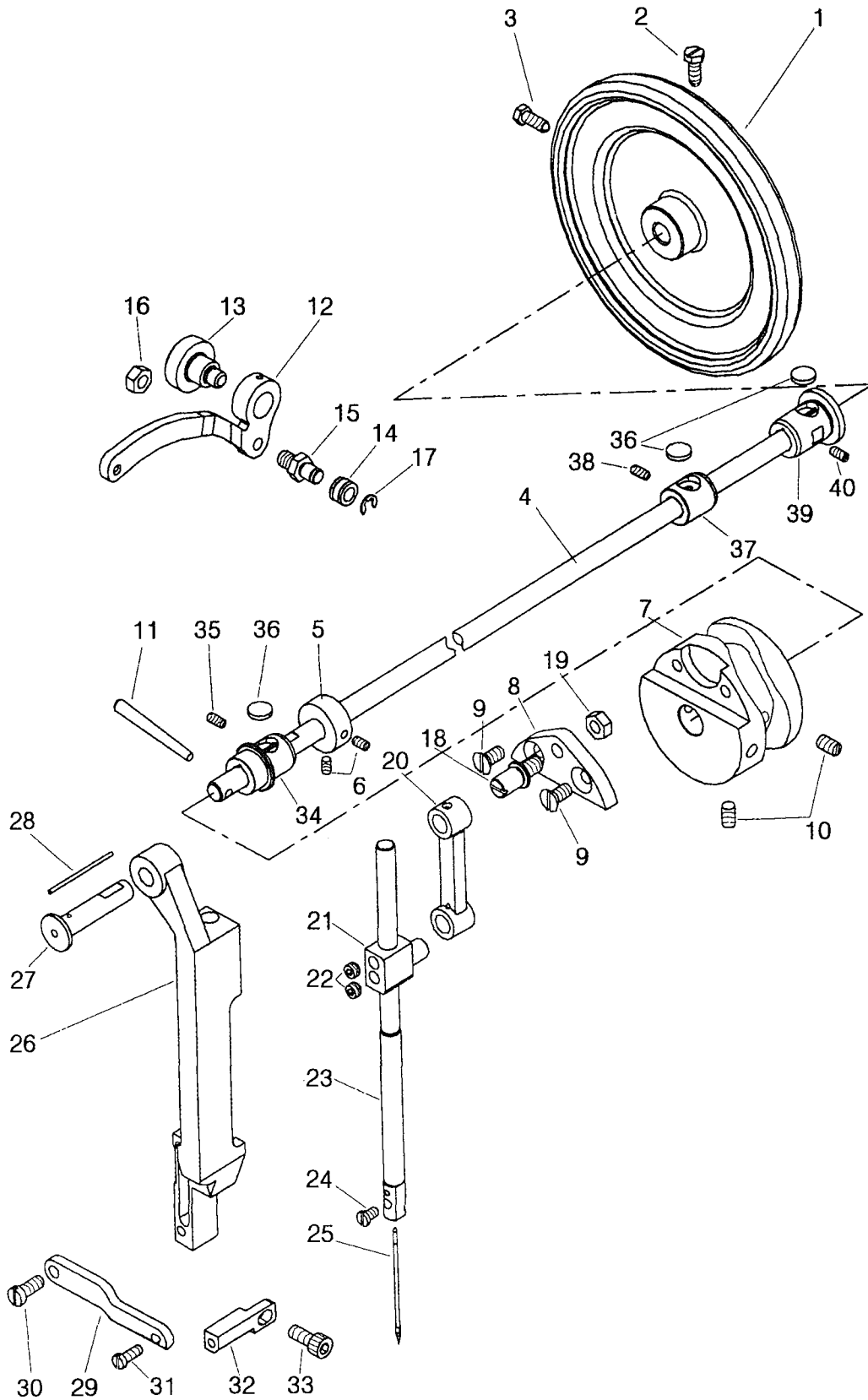

B.NEEDLE BAR AND THREAD TAKE-UP MECHANISM

Fig. No.	Part No.	Description	Pcs.	Remarks
B01	H7204C8001	Pulley	1	
B02	H7205C8001	Screw	1	SM5/16(24)×19
B03	H7206C8001	Screw	1	SM5/16(24)×19
B04	H8905C8001	Arm shaft	1	
B05	HA108G0661	Collar	1	
B06	HA105D0662	Set Screw	2	SM1/4(40)×6
B07	H7209C8001	Thread take-up cam	1	
B08	H7210C8001	Needle bar connecting base link screw	1	
B09	H403060120	Screw	2	GB/T68 M6×12
B10	H4933K8001	Set Screw	2	SM1/4(40)×10
B11	H602040450	Pin	1	GB/T117 4×45
B12	H7211C8001	Thread take-up lever	1	
B13	H7212C8001	Screw	1	SM5/16(24)×7.5
B14	H7213C8001	Roller	1	
B15	H7214C8001	Roller pin	1	
B16	H2010J0066	Nut	1	SM9/32(28)
B17	H007013050	Retaining ring-E type	1	GB/T896 5
B18	H7215C8001	Needle bar connecting link screw	1	SM9/32(28)×11.5
B19	H2010J0066	Nut	1	SM9/32(28)
B20	H7216C8001	Needle bar connecting link	1	
B21	H7217C8001	Needle bar connecting stud	1	
B22	H7218C8001	Set Screw	2	SM1/4(40)×4.5
B23	H7219C8001	Needle bar	1	
B24	HA700F2100	Screw	1	SM11/64(40)×7
B25	H7220C8001	Needle	1	DY*3 26#
B26	H7222C8001	Needle bar guide bracket	1	
B27	H7223C8001	Needle bar guide bracket pin	1	
B28	H7224C8001	Oil wick	1	
B29	H7225C8001	Needle bar guide bracket plate	1	
B30	H3208G0676	Screw	1	SM15/64(28)×10.5
B31	HA111G0683	Screw	1	SM11/64(40)×12
B32	H7226C8001	Needle bar guide bracket plate base	1	
B33	H415060140	Screw	1	GB/T70.1 M6×14
B34	H7213B8001	Bushing	1	
B35	H2405D0664	Set Screw	1	SM15/64(28)×14
B36	H7214B8001	Felt	3	
B37	H7212B8001	Bushing	1	
B38	H2405D0664	Set Screw	1	SM15/64(28)×14
B39	H7211B8001	Bushing	1	
B40	H2405D0664	Set Screw	1	SM15/64(28)×14

C.LOWER SHAFT MECHANISM

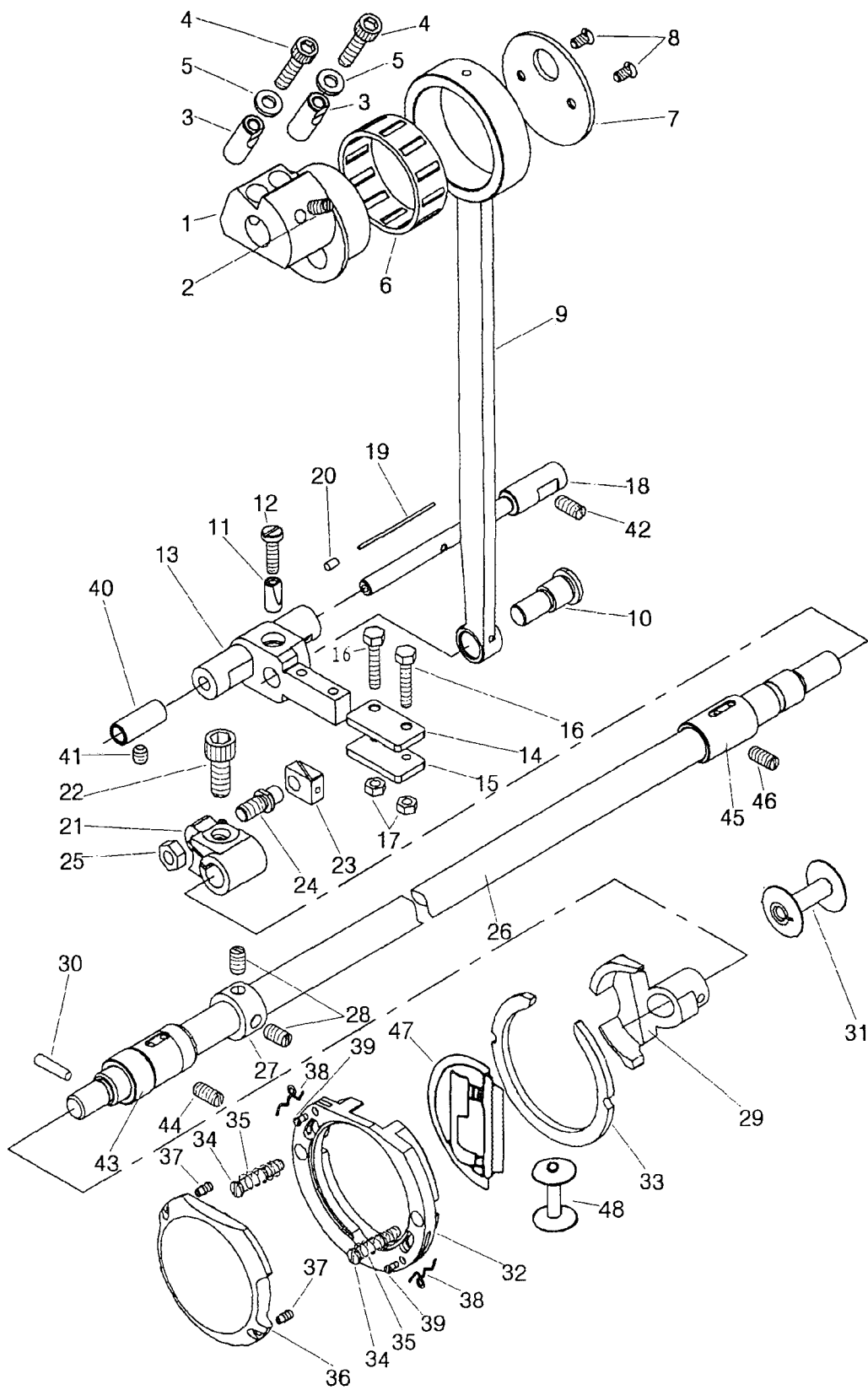

C.LOWER SHAFT MECHANISM

Fig. No.	Part No.	Description	Pcs.	Remarks
C01	H7204D8001	Eccentric	1	
C02	H7205D8001	Set Srew	1	SM15/64(28)×12
C03	H7206D8001	pin	2	
C04	H415060250	Screw	2	GB/T70.1 M6×25
C05	H4728H8001	Washer	2	
C06	H7237D8001	Bearing	1	K43×48×17(NTN)
C07	H7207D8001	Eccentric cover	1	
C08	H2000B2050	Screw	2	SM11/64(40)×9
C09	H7208D8001	Crank connecting rod	1	
C10	H7209D8001	Crank connecting rod pin	1	
C11	H7210D8001	Pin	1	
C12	H7211D8001	Screw	1	SM3/16(32)×18
C13	H7213D8001	Shuttle shaft	1	
C14	H7214D8001	Plate	1	
C15	H7215D8001	Plate	1	
C16	H7216D8001	Screw	2	SM11/64(40)
C17	H2000M0120	Nut	2	SM11/64(40)
C18	H7218D8001	Inside Shaft	1	
C19	H7219D8001	Oil wick	1	
C20	H7220D8001	Rivet	1	
C21	H7222D8001	Lower shaft crank	1	
C22	H415080200	Screw	1	GB/T70.1 M8×20
C23	H7223D8001	Shuttle shaft slide block	1	
C24	H7224D8001	Screw	1	
C25	H2010J0066	Nut	1	SM9/32(28)
C26	H8905D8001	Lower shaft	1	
C27	HA108G0661	Collar	1	
C28	H7239D8001	Set Screw	2	SM1/4(40)×3.5
C29	H7227D8001	Shuttle driver	1	
C30	H602040180	Pin	1	GB/T117 4×18
C31	H7228D8001	Bobbin	1	
C32	H7229D8001	Shuttle race body	1	
C33	H7230D8001	Shuttle race back ring	1	
C34	H7231D8001	Screw	2	SM3/16(32)
C35	H7232D8001	Spring	2	
C36	H7233D8001	Shuttle race cap	1	
C37	H7234D8001	Screw	2	SM1/8(44)
C38	H7235D8001	Spring	2	
C39	H7236D8001	Screw	2	SM3/32(56)
C40	H7234B8001	Bushing	1	
C41	HA3411D308	Set Screw	1	SM15/64(28)×7
C42	HA100C2020	Set Screw	1	SM15/64(28)×10
C43	H7230B8001	Bushing	1	

C.LOWER SHAFT MECHANISM

Fig. No.	Part No.	Description	Pcs.	Remarks
C44	H2405D0664	Set Screw	1	SM15/64(28)×14 SM15/64(28)×14 KSP-204N (佐文)
C45	H7229B8001	Bushing	1	
C46	H2405D0664	Set Screw	1	
C47	H7240D8001	Shuttle hook complete	1	
C48	H7228D8001	Bobbin	1	

D.FEEDING MECHANISM

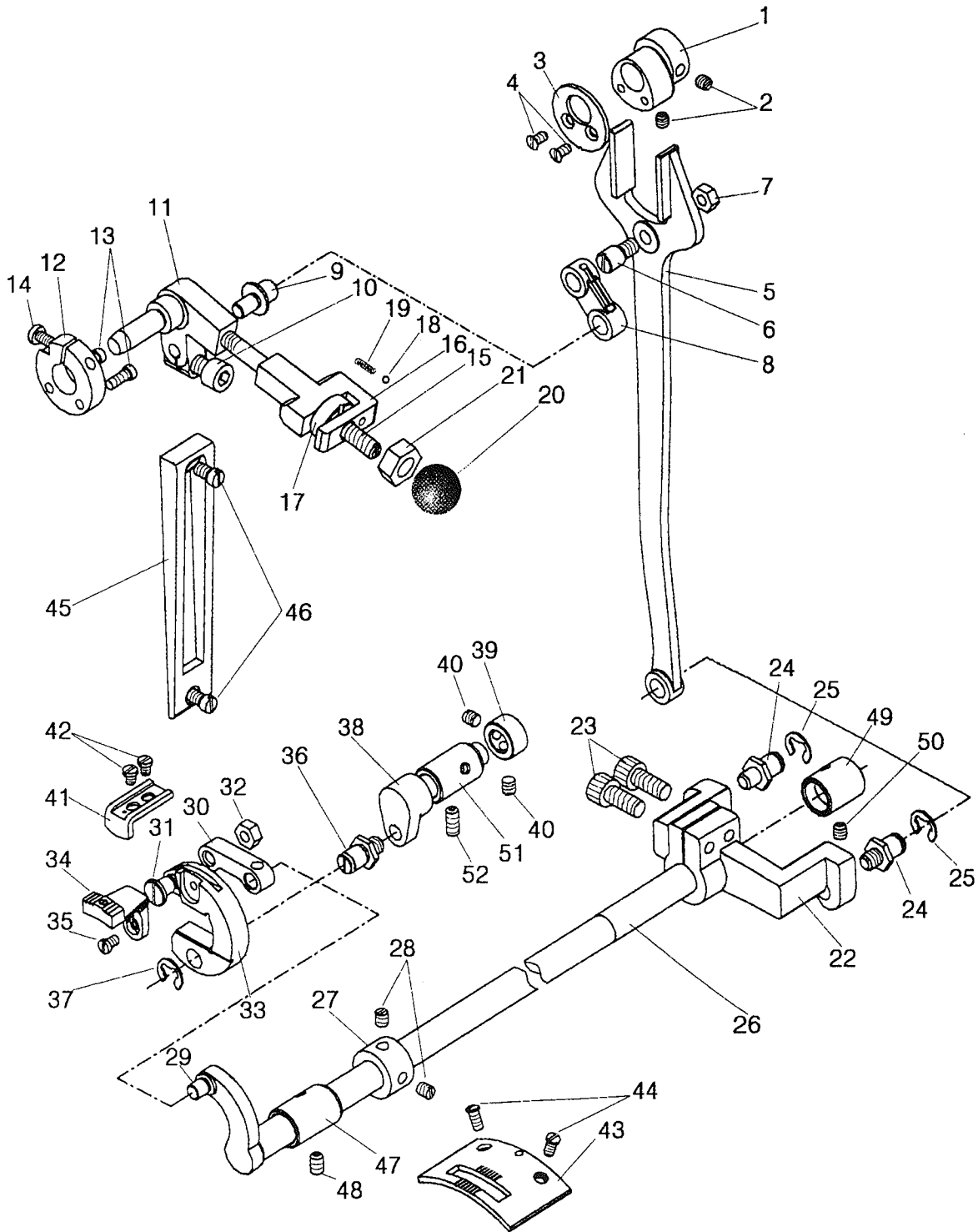

D.FEEDING MECHANISM

Fig. No.	Part No.	Description	Pcs.	Remarks
D01	H7205E8001	Feed cam	1	
D02	H7206E8001	Set Screw	2	SM15/64(28)×6
D03	H7207E8001	Feed cam cover	1	
D04	H2000B2050	Screw	2	SM11/64(40)×9
D05	H7208E8001	Feed forked connection	1	
D06	H7209E8001	Feed forked connection crank pin	1	
D07	H2010J0066	Nut	1	SM9/32(28)
D08	H7210E8001	Stitch length connecting link	1	
D09	H7211E8001	Stitch length connecting link crank pin	1	
D10	H415050140	Screw	1	GB/T70.1 M5×14
D11	H7212E8001	Stitch length adjusting pin	1	
D12	H7213E8001	Damping plate	1	
D13	HA104G0012	Screw	2	SM3/16(28)×12
D14	H7211D8001	Screw	1	SM3/16(32)×18
D15	H7214E8001	Stitch length adjusting bolt	1	
D16	H7215E8001	Stitch length limited plate	1	
D17	H7216E8001	Nut	1	
D18	HE00001032	Metal ball	1	GB/T308 3.175
D19	H7217E8001	Spring	1	
D20		Plastic ball	1	JB/T7271.1 M8×32 黑色
D21	H003008080	Nut	1	GB/T6172.1 M8
D22	H7218E8001	Feed driving rock shaft crank	1	
D23	H415060200	Screw	2	GB/T70.1 M6×20
D24	H7219E8001	Feed driving rock shaft crank pin	2	
D25	H007013080	Retaining ring-E type	2	GB/T896 8
D26	H8904E8001	Feed driving rock shaft	1	
D27	HA108G0661	Collar	1	
D28	H7239D8001	Set Screw	2	SM1/4(40)×3.5
D29	H7221E8001	Crank pin	1	
D30	H7222E8001	Feed driving connecting link	1	
D31	H7223E8001	Feed driving connecting link crank pin	1	
D32	H2013N0067	Nut	1	SM1/4(24)
D33	H7225E8001	Feed dog base	1	
D34	H7226E8001	Feed dog	1	
D35	HA700F2100	Screw	1	SM11/64(40)×7
D36	H7219E8001	Feed lifting rock shaft crank pin	1	
D37	H007013080	Retaining ring-E type	1	GB/T896 8
D38	H7227E8001	Feed lifting rock shaft	1	
D39	H7228E8001	Collar	1	
D40	H7239D8001	Set Screw	2	SM1/4(40)×3.5
D41	H7229E8001	Feed dog base limited plate	1	
D42	H5711G8001	Screw	2	SM11/64(40)×6
D43	H7230E8001	Needle plate	1	

D.FEEDING MECHANISM

Fig. No.	Part No.	Description	Pcs.	Remarks
D44	H7231E8001	Screw	2	SM3/16(28)×9.5
D45	H7232E8001	Stitch length indicating plate	1	
D46	HA104F0654	Screw	2	SM15/64(28)×9
D47	H7232B8001	Bushing	1	
D48	HA100C2020	Set Screw	1	SM15/64(28)×10
D49	H7231B8001	Bushing	1	
D50	HA3411D308	Set Screw	1	SM15/64(28)×7
D51	H7233B8001	Bushing	1	
D52	H2405D0664	Set Screw	1	SM15/64(28)×14

E.UPPER SHAFT & PRESSER FOOT MECHANISM

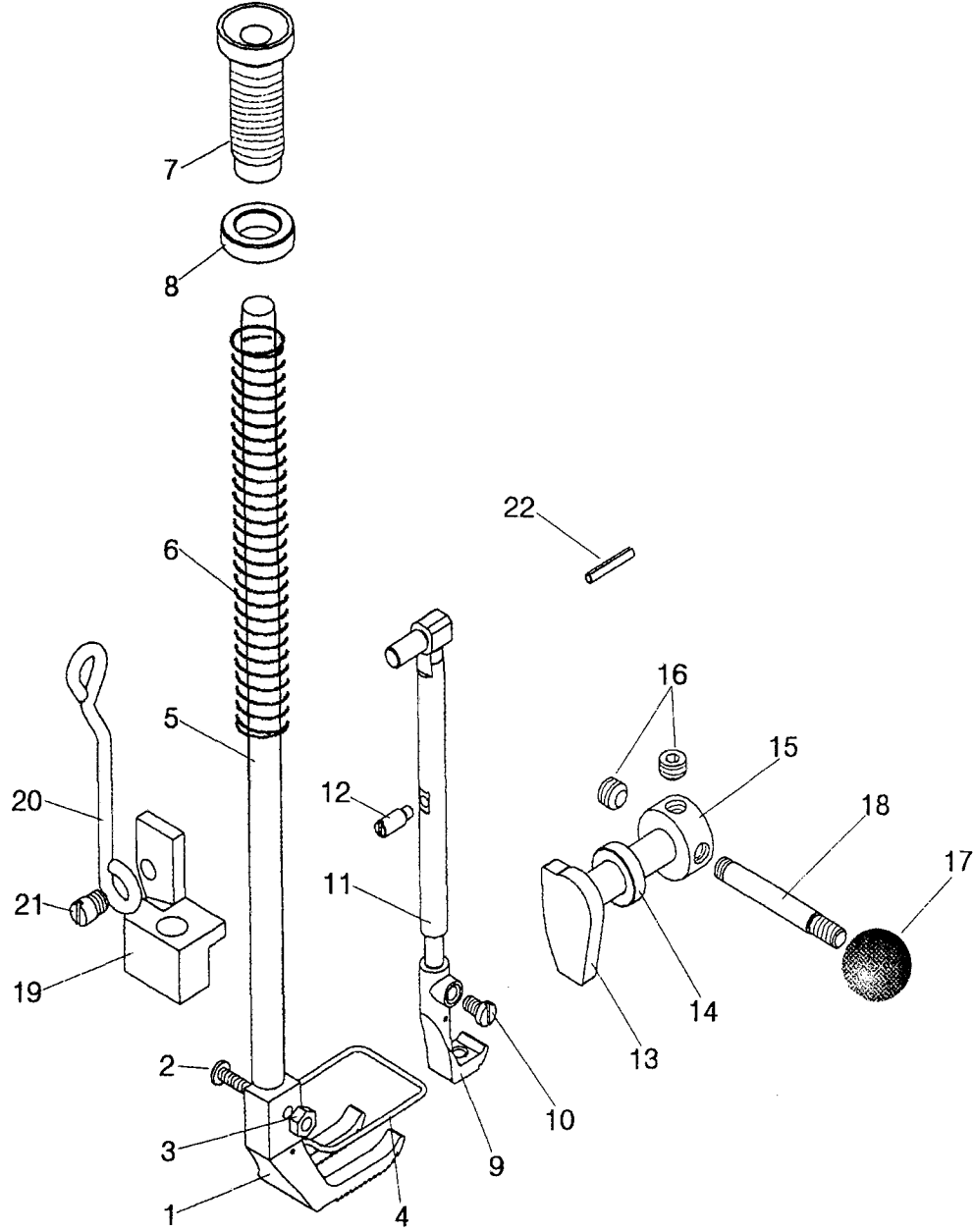

E.PRESSER FOOT MECHANISM

Fig. No.	Part No.	Description	Pcs.	Remarks
E01	H7204F8001	Presser foot	1	
E02	H7205F8001	Screw	1	SM9/64(40)×14
E03	HA710P0673	Nut	1	SM9/64(40)
E04	H7206F8001	Finger guard	1	
E05	H7207F8001	Presser bar	1	
E06	H7208F8001	Presser bar spring	1	
E07	H7209F8001	Thumb screw	1	SM5/8(28)
E08	H7210F8001	Nut	1	SM5/8(28)
E09	H7211F8001	Walking foot	1	
E10	HA719B0709	Screw	1	SM11/64(40)×7
E11	H7212F8001	Presser bar	1	
E12	H7213F8001	Screw	1	SM9/64(40)
E13	H7214F8001	Presser bar lifting shaft	1	
E14	H7215F8001	Washer	1	
E15	H7217F8001	Collar	1	
E16	H7218C8001	Set Screw	2	SM1/4(40)×4.5
E17		Plastic ball	1	JB/T7271.1 M6×20
E18	H7219F8001	Bolt	1	
E19	H7220F8001	Presser bar guide bracket	1	
E20	H7221F8001	Connecting rod	1	
E21	H7222F8001	Screw	1	SM1/4(40)
E22	H609030180	Pin	1	GB/T879.1 3×18

F. UPPER FEED LIFTING ROCK SHAFT MECHANISM

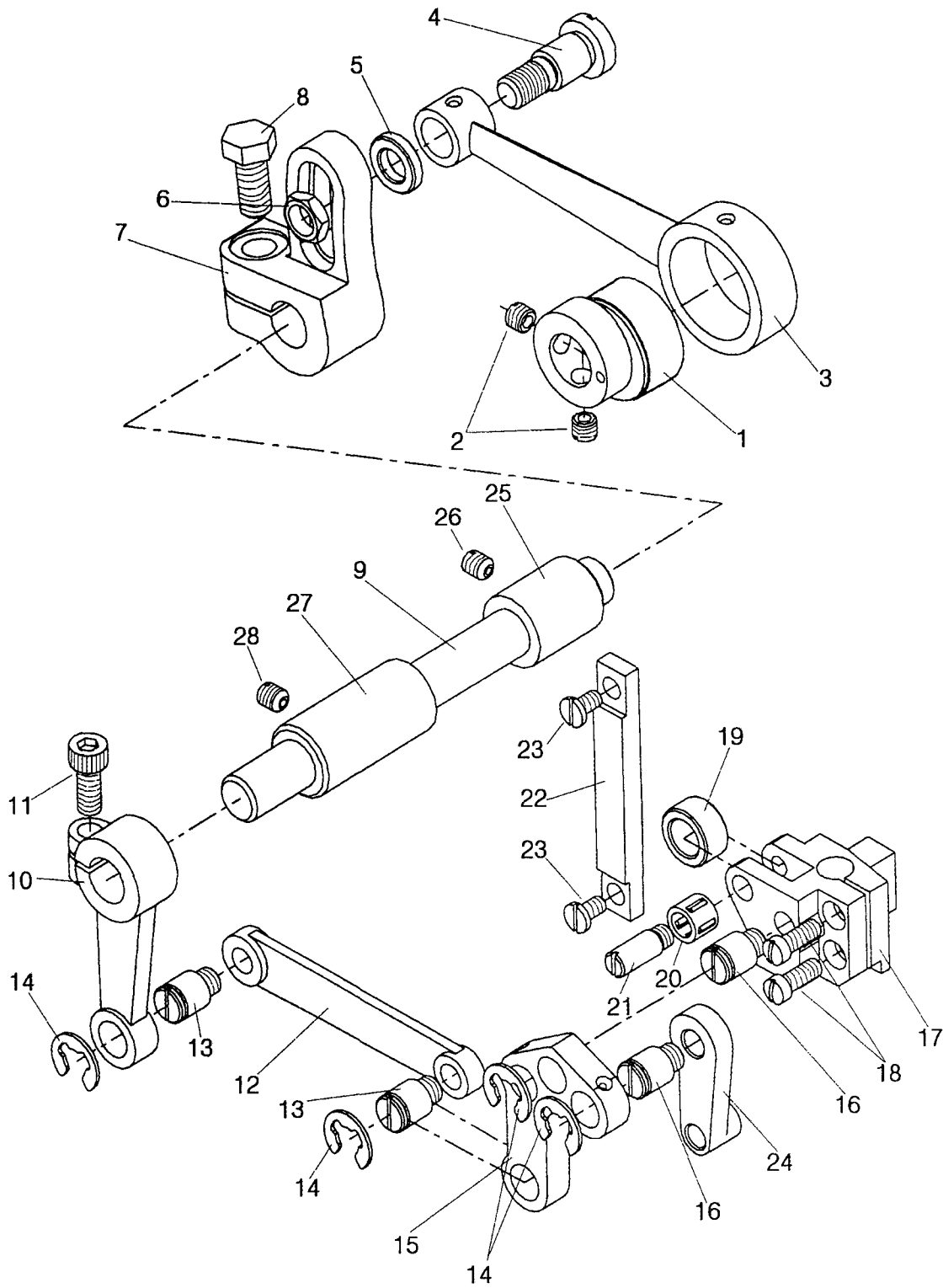

F.UPPER FEED LIFTING ROCK SHAFT MECHANISM

Fig. No.	Part No.	Description	Pcs.	Remarks
F01	H7204G8001	Presser foot lifting eccentric	1	
F02	HA307C0066	Set Screw	2	SM1/4(40)×6
F03	H7205G8001	Eccentric connecting link	1	
F04	H7206G8001	Screw	1	
F05	H7207G8001	Washer	1	
F06	H7208G8001	Nut	1	SM11/32(28)
F07	H7209G8001	Adjusting crank	1	
F08	H7210G8001	Screw	1	SM5/16(18)
F09	H7211G8001	Presser foot lifting shaft	1	
F10	H7212G8001	Presser foot lifting shaft crank	1	
F11	H415060140	Screw	1	GB/T70.1 M6×14
F12	H7213G8001	Presser foot lifting connecting link	1	
F13	H7214G8001	Screw	2	
F14	H007013080	Retaining ring-E type	4	GB/T896 8
F15	H7215G8001	Presser foot lifting lever	1	
F16	H7214G8001	Screw	2	
F17	H7216G8001	Presser foot lifting lever base	1	
F18	HA104G0012	Screw	2	SM3/16(28)×12
F19	H7217G8001	Roller	1	
F20	H7221G8001	Bearing	1	ISO K7
F21	H7218G8001	Screw	1	SM15/64(28)
F22	H7219G8001	Roller base plate	1	
F23	HA700B2060	Screw	2	SM3/16(32)×8
F24	H7220G8001	Walking foot lifting connecting link	1	
F25	H7221B8001	Bushing	1	
F26	HA3411D308	Set Screw	1	SM15/64(28)×7
F27	H7222B8001	Bushing	1	
F28	HA3411D308	Set Screw	1	SM15/64(28)×7

G.NEEDLE BAR ROCKING MOTION MECHANISM

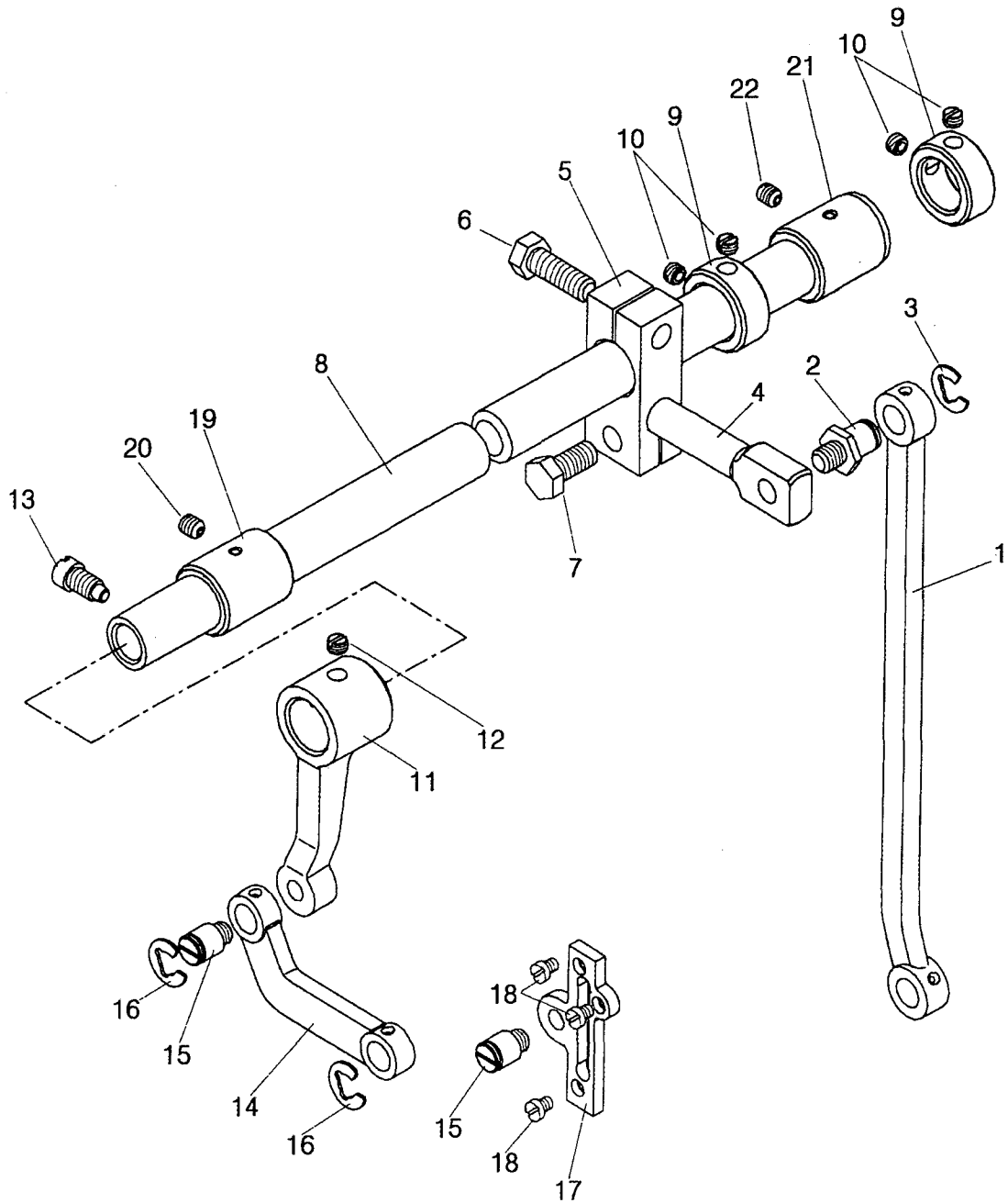

G.NEEDLE BAR ROCKING MOTION MECHANISM

Fig. No.	Part No.	Description	Pcs.	Remarks
G01	H7204H8001	Needle bar rocking connecting link	1	
G02	H7219E8001	Screw	1	
G03	H007013080	Retaining ring-E type	1	GB/T896 8
G04	H7206H8001	Adjusting crank	1	
G05	H7207H8001	Adjusting crank base	1	
G06	H7208H8001	Screw	1	SM5/16(18)×24
G07	H7210G8001	Screw	1	SM5/16(18)×18
G08	H8904H8001	Needle bar rock shaft	1	
G09	H7210H8001	Collar	2	
G10	HA105D0662	Set Screw	4	SM1/4(40)×4.5
G11	H7211H8001	Needle bar rocking crank	1	
G12	HA105D0662	Set Screw	1	SM1/4(40)×4.5
G13	HA100C2070	Screw	1	SM9/32(28)
G14	H7212H8001	Needle bar rocking connecting link	1	
G15	H7214G8001	Screw	2	
G16	H007013080	Retaining ring-E type	2	GB/T896 8
G17	H7213H8001	Screw base	1	
G18	H7214H8001	Screw	3	SM11/64(40)×4.5
G19	H7224B8001	Bushing	1	
G20	HA3411D308	Set Screw	1	SM15/64(28)×7
G21	H7223B8001	Bushing	1	
G22	HA3411D308	Set Screw	1	SM15/64(28)×7

H.KNEE LIFTER MECHANISM

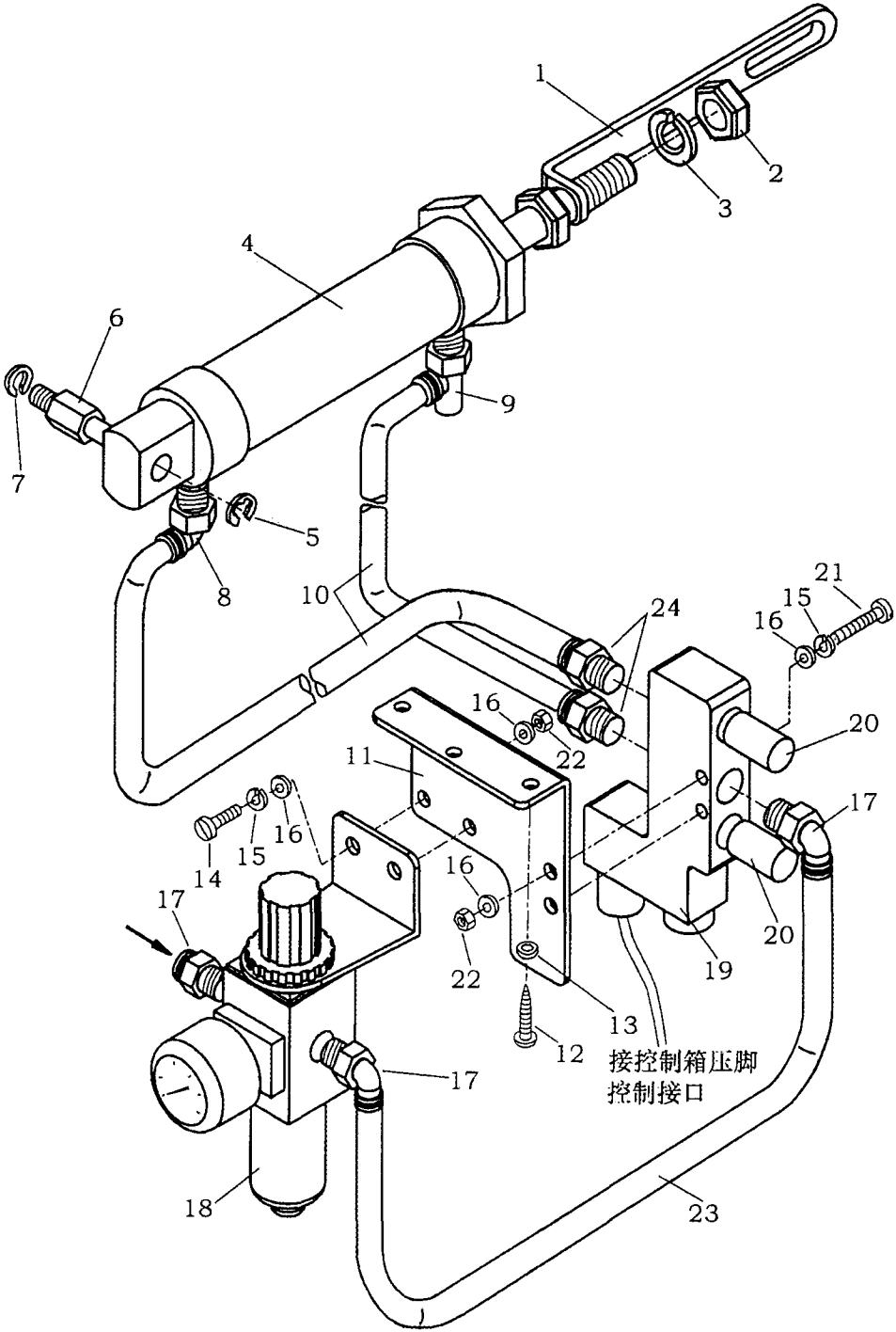

H.KNEE LIFTER MECHANISM

Fig. No.	Part No.	Description	Pcs.	Remarks
H01	H8906I8001	Cylinder bar	1	
H02		Nut	1	GB/T6173 M10×1.25
H03	H005008100	Spring Washer	1	GB/T93 10
H04	H4910N8001	Cylinder	1	MAL25×50
H05	H007013060	E type ring	1	GB/T896 6
H06	H8907I8001	Swing Pin	1	
H07	H005008080	Spring Washer	1	GB/T93 8
H08	H4921N8001	Tube Fitting	1	φ 6-1/8"
H09	H4922N8001	Timing valve	1	φ 6-1/8"
H10	H8908I8001	PU Tube	2	φ 6(1.6m)
H11	H4923N8001	Bracket for filtration and decompression	1	
H12	H801045200	Screw	2	GB/T99 4.5×20
H13	HA300J2230	Washer	2	
H14	H402040120	Screw	2	GB/T67 M4×12
H15	H005008040	Spring washer	4	GB/T93 4
H16	H005005040	Washer	8	GB/T95 4
H17	H8909I8001	Tube Fitting	3	φ 8-1/4"
H18	H4915N8001	Valve for filtration and decompression	1	
H19	H4918N8001	Solenoid Valve	1	DC24V
H20	H4924N8001	Silencer	2	
H21	H402040300	Screw	2	GB/T67 M4×30
H22	H003002040	Nut	4	GB/T6170 M4
H23	H8910I8001	PU Tube	1	φ 8(0.2m)
H24	H4917N8001	Tube Fitting	2	φ 6-1/4"

I.KNEE LIFTER MECHANISM

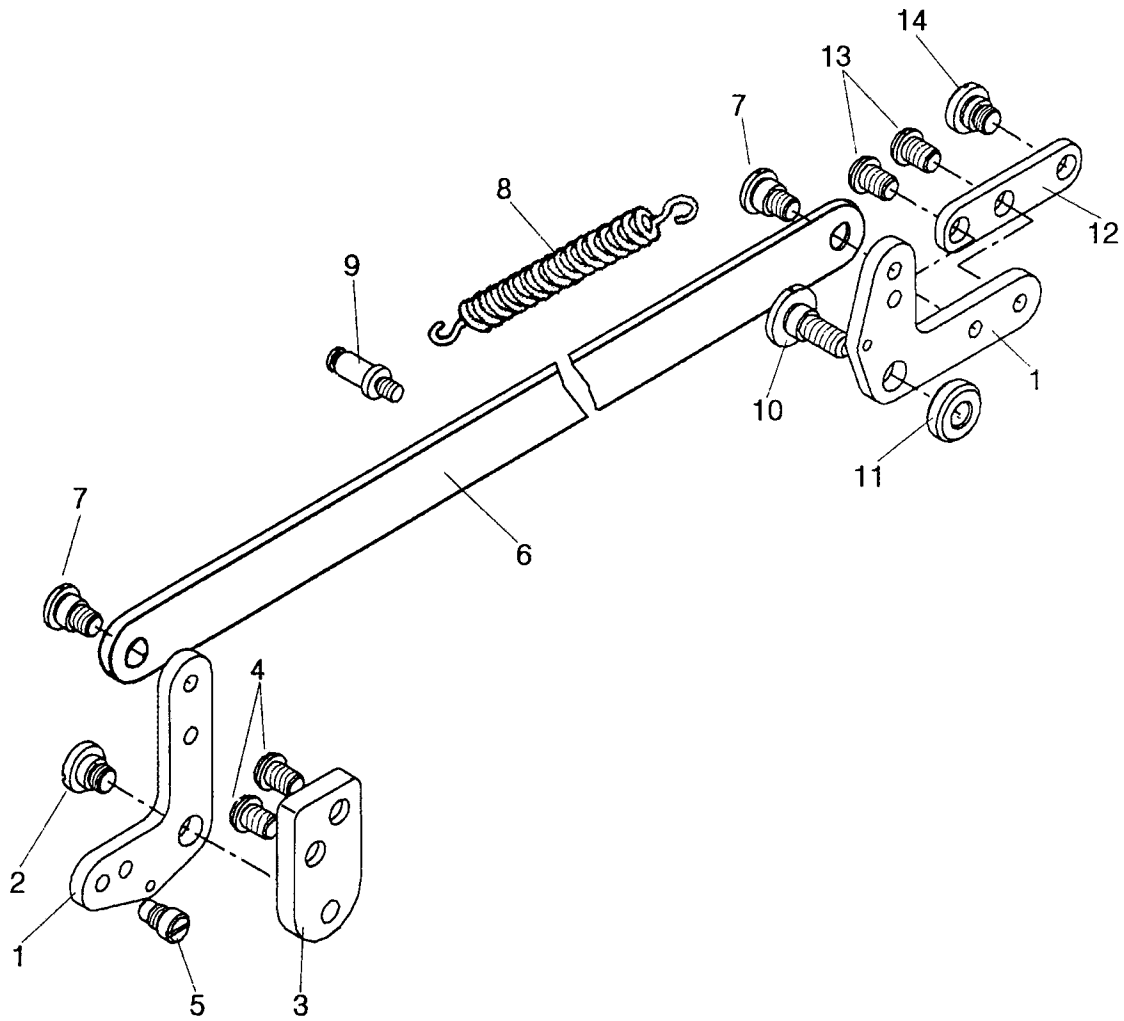

I.KNEE LIFTER MECHANISM

Fig. No.	Part No.	Description	Pcs.	Remarks
I01	H7204I8001	Knee lifter lever	2	
I02	H7205I8001	Screw	1	SM15/64(28)×6
I03	H7206I8001	Knee lifter lever base	1	
I04	HA300J2280	Screw	2	SM15/64(28)×8
I05	H7207I8001	Screw	1	SM15/64(28)
I06	H8904I8001	Knee lifter rod	1	
I07	H7205I8001	Screw	2	SM15/64(28)×6
I08	H7209I8001	Coil spring	1	
I09	H7210I8001	Screw	1	SM11/64(40)×6
I10	H7211I8001	Screw	1	SM11/64(40)×4.5
I11	H7212I8001	Washer	1	
I12	H7214I8001	Knee lifter lever connecting plate	1	
I13	HA300J2280	Screw	2	SM15/64(28)×8
I14	H7213I8001	Screw	1	SM1/4(40)×3.5

J.BOBBIN WINDER MECHANISM

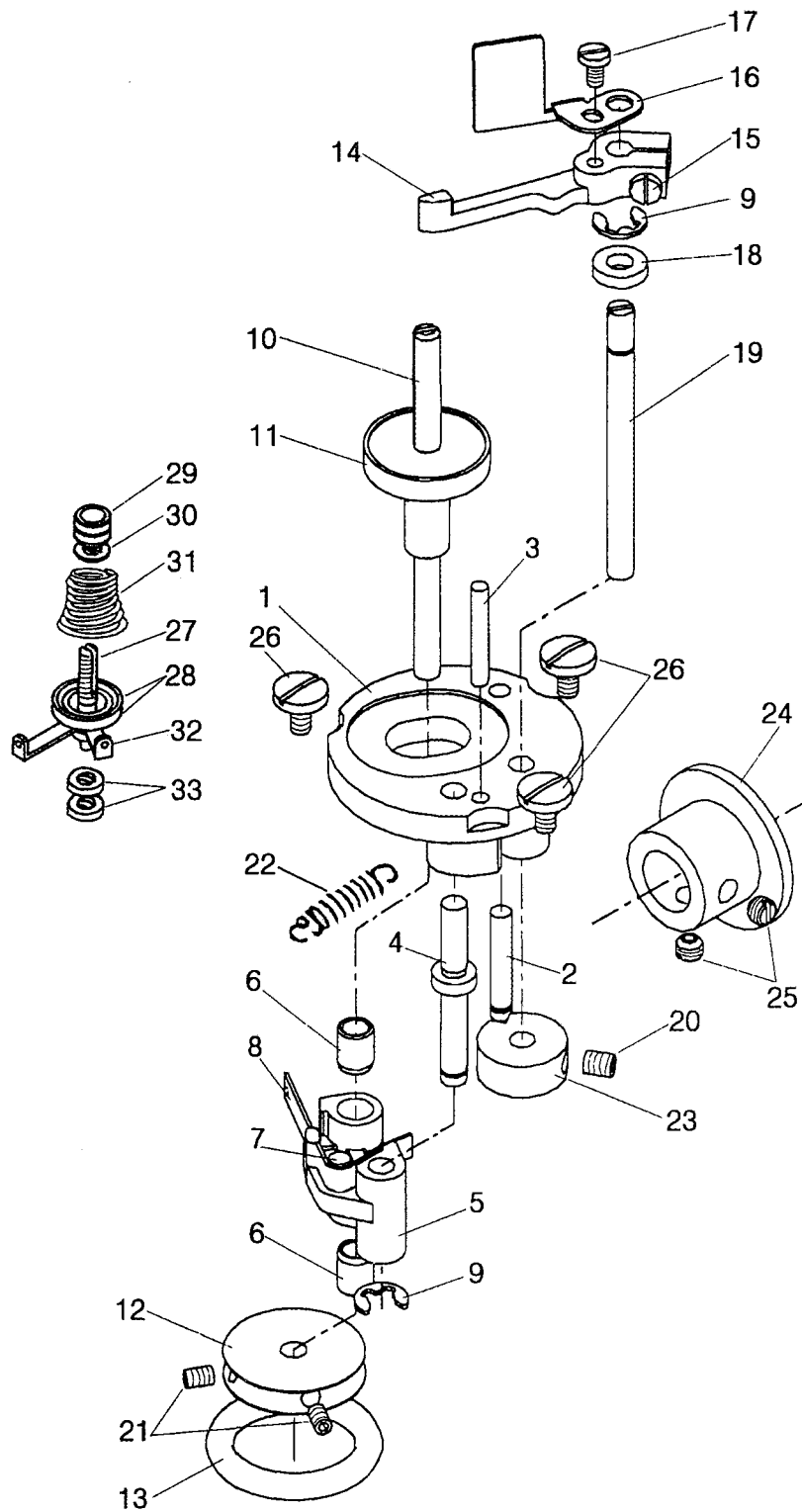

J.BOBBIN WINDER MECHANISM

Fig. No.	Part No.	Description	Pcs.	Remarks
J01	H6706N8001	Bobbin winder plate	1	
J02	H6707N8001	Pin	1	
J03	H6708N8001	Pin	1	
J04	H7210J8001	Bobbin winder crank shaft	1	
J05	H7213J8001	Bobbin winder crank	1	
J06	H6713N8001	Bushing	2	
J07	H6714N8001	Pin	1	
J08	H6715N8001	Bobbin winder spring	1	
J09	H007013050	Retaining ring-E type	2	GB/T896 5
J10	H7205J8001	Bobbin winder shaft	1	
J11	H6717N8001	Bobbin base	1	
J12	H6718N8001	Driven wheel	1	
J13	H6719N8001	Friction rubber band	1	
J14	H6720N8001	Bobbin winder lever	1	
J15	HA100H2150	Screw	1	SM9/64(40)×11
J16	H7206J8001	Winding length limited plate	1	
J17	H3200B2100	Screw	1	
J18	H6722N8001	Washer	1	
J19	H6723N8001	Pin	1	
J20	H6731N8001	Set Screw	1	M5×6
J21	H6732N8001	Set Screw	2	GB/T 80 M3×4
J22	H6724N8001	Spring	1	
J23	H6725N8001	Bobbin winder cam	1	
J24	H7005D8001	Driving wheel	1	
J25	H4723D8001	Set Screw	2	SM15/64(28)
J26	H3107G0662	Screw	3	SM11/64(40)
J27	H7208J8001	Screw	1	
J28	HA310B0705	Tension disc	2	
J29	HA115B0702	Nut	1	
J30	HA115B7010	Limited plate	1	
J31	H3300B2040	Spring	1	
J32	H6662B8001	Thread guide	1	
J33	H003008040	Nut	2	GB/T6172.1 M4

K.ACCESSORIES(一)

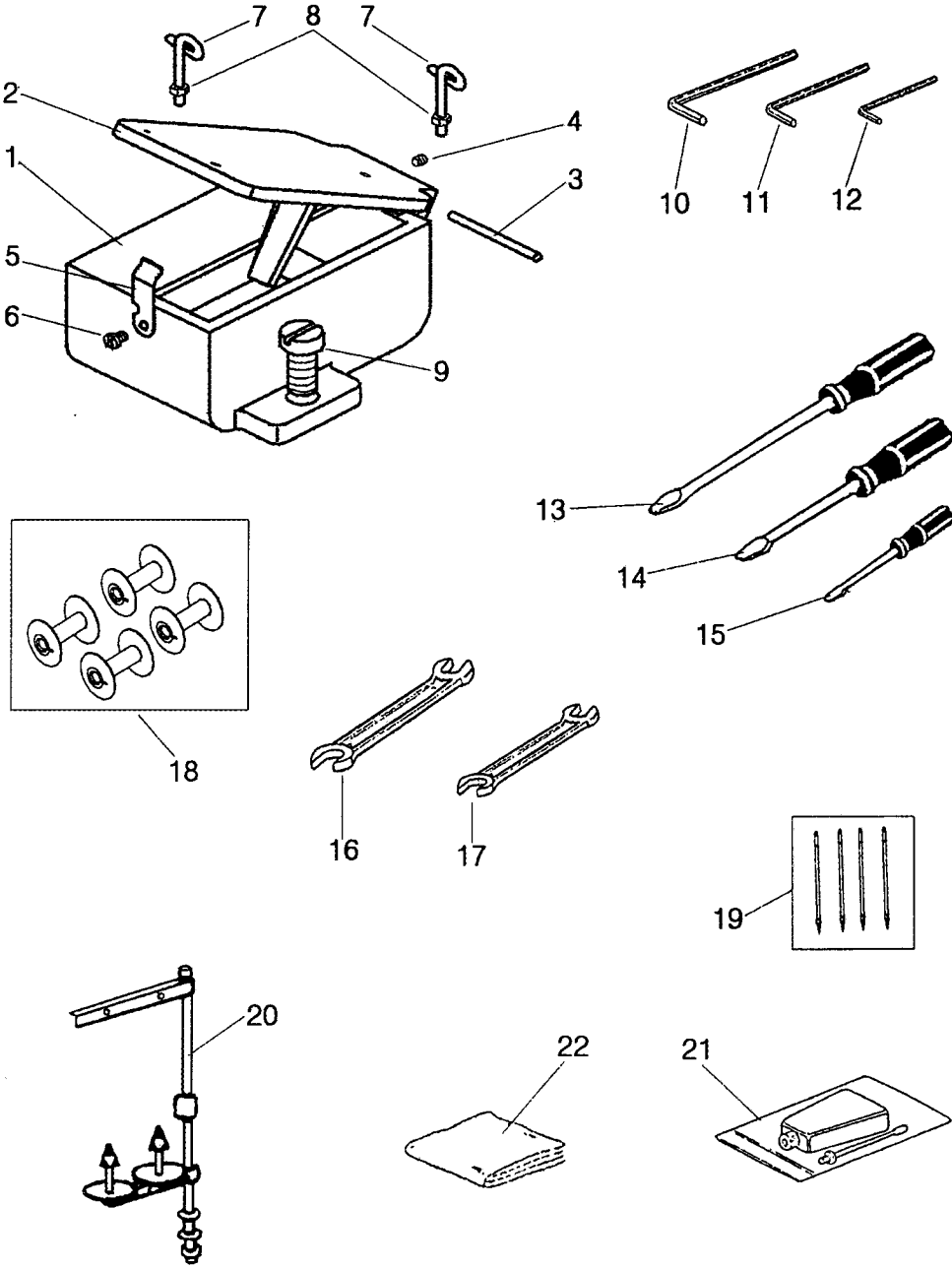

K.ACCESSORIES(一)

Fig. No.	Part No.	Description	Pcs.	Remarks
K01	H7207K8001	Silicon oil box	1	
K02	H7208K8001	Cover	1	
K03	H605030400	Pin	1	GB/T119.2 3×40
K04	H34411C410	Screw	1	SM9/64(40)×4
K05	H7209K8001	Spring	1	
K06	H3215K0693	Screw	1	SM9/64(40)×5
K07	H7210K8001	Thread guide	2	
K08	H7211K8001	Nut	2	SM3/32(56)
K09	HA800F2020	Screw	1	SM15/64(28)
K10	HB00001050	Hexagon socket screw key	1	GB/T5356 5
K11	HB00001040	Hexagon socket screw key	1	GB/T5356 4
K12	HB00001030	Hexagon socket screw key	1	GB/T5356 3
K13	HA300J2070	Screw driver (size L)	1	
K14	HA300J2200	Screw driver (size M)	1	
K15	HA300J2210	Screw driver (size S)	1	
K16	HJ02090110	Spanner	1	GB/T4388 9×11
K17	HJ02100130	Spanner	1	GB/T4388 10×13
K18	H7228D8001	Bobbin	4	
K19	H7220C8001	Needle	4	
K20	HA200J2030	Thread stand assy	1	
K21	H200400069	Oiler	1	
K22	H8904K8001	Vinyl cover	1	

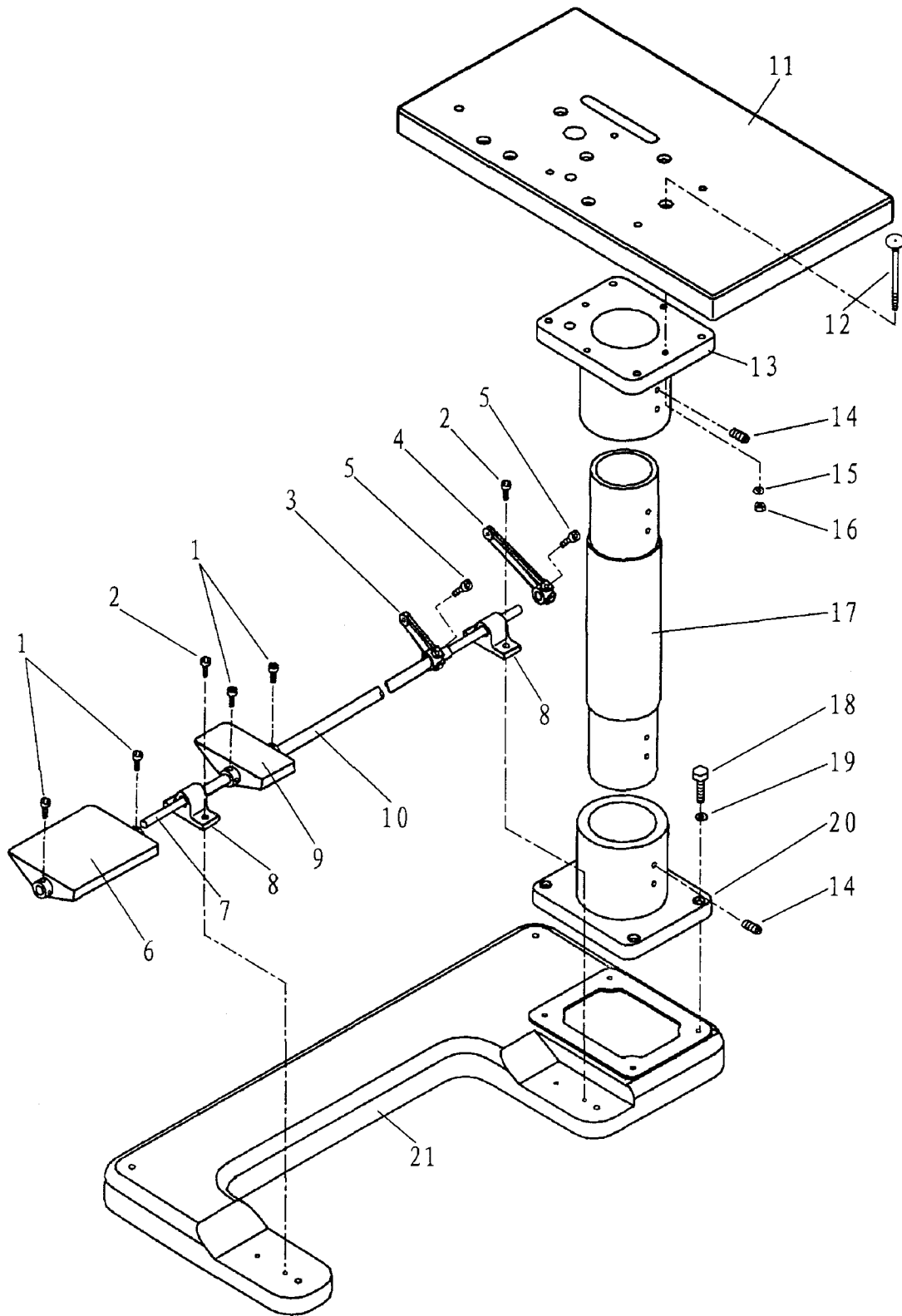

L.ACCESSORIES(二)

Fig. No.	Part No.	Description	Pcs.	Remarks
L01	H415060140	Screw	8	GB/T70.1 M6×14
L02	H103080250	Screw	4	GB/T5782 M8×25
L03	H8918K8001	Short rod	1	
L04	H8917K8001	Long rod	1	
L05	H415080160	Screw	4	GB/T70.1 M8×16
L06	H8924K7101	Large pedal	1	
L07	H8920K8001	Long steel tube	1	
L08	H8913K8001	Steel tube base	2	
L09	H8924K7101	Small pedal	1	
L10	H8918K8001	Short steel tube	1	
L11	H8910K8001	Bedplate	1	
L12	H125100900	Screw	4	GB/T14 M10×90
L13	H8915K8001	Flange	1	
L14	H429120250	Set Screw	4	GB/T78 M12×25
L15	H005001100	Washer	4	GB/T97.1 10
L16	H003002100	Nut	4	GB/T6170 M10
L17	H8912K8001	Connecting steel tube	1	
L18	H103120500	Screw	4	GB/T5782 M12×50
L19	H005008120	Spring washer	4	GB/T93 12
L20	H8916K8001	Flange	1	
L21	H8911K8001	Operation base	1	

SHANGHAI HUIGONG NO.3 SEWING MACHINE FACTORY

ADD: 1418, Yishan Road, Shanghai, China

Zip Code: 201103

Overseas Business: TEL: 86-21-64853303 FAX: 86-21-64854304

E-mail: highlead@online.sh.cn <http://www.highlead.com.cn>

The description covered in this manual is subject to change for improvement of the commodity without notice

2004.2. Printed